

FP40515CLB-3-11 Combine preselector, 11 MHz B.W., BNC-female connector, 746-757 MHz

- Covers the entire 746-757 MHz frequency range
- 1.5 dB insertion loss over the pass band
- 60 dB attenuation at 776 MHz

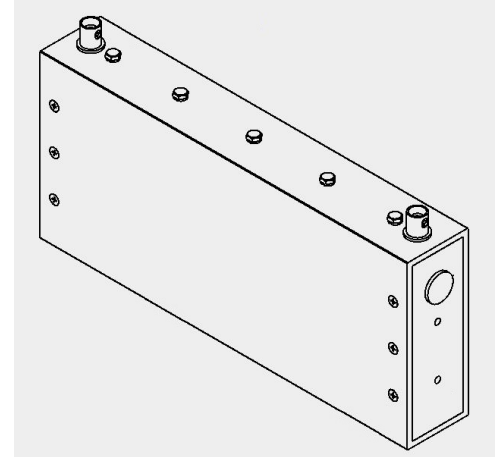

www.sinctech.com

Region	United States	Europe, Middle East and Africa	Caribbean and Latin America	Canada and rest of the world
<b>Telephone</b>	USA: 1 800 263 3275	International: +44 (0) 1487 84 28 19	International: +1 905 726 7676	Canada: 1 800 263 3275 International: +1 905 727 0165
<b>E-mail</b>	salesusa@sinctech.com	salesuk@sinctech.com	salesla@sinctech.com	salescan@sinctech.com
Product Specification Sheet EPR 018248		FP40515CLB-3-11	Issue: 16	Dated: 17-03-17 Dated: 03-02-17

### Electrical Specifications

Frequency Range	MHz	746 to 757
Input VSWR (max)		1.5:1
Bandwidth at specified insertion loss	MHz	11
Pass band Insertion Loss (max)	dB	1.5
Impedance	Ω	50
Input Connectors		BNC-Female
Output Connectors		BNC-Female

### Mechanical Specifications

Width	in (mm)	8.25 (210)
Depth	in (mm)	5 (127)
Length/ Height	in (mm)	1.5 (38)
Mounting configurations		Panel

### Environmental Specifications

Temperature range	°F (°C)	-22 to +140 (-30 to +60)
-------------------	---------	--------------------------

www.sinctech.com

Region	United States	Europe, Middle East and Africa	Caribbean and Latin America	Canada and rest of the world
<b>Telephone</b>	USA: 1 800 263 3275	International: +44 (0) 1487 84 28 19	International: +1 905 726 7676	Canada: 1 800 263 3275 International: +1 905 727 0165
<b>E-mail</b>	salesusa@sinctech.com	salesuk@sinctech.com	salesla@sinctech.com	salescan@sinctech.com